

MAXXUM 80T
80 LBS. THRUST
24 Volt 56 Amp
42" SHAFT

for use with "AI" serial numbers
3- year warranty from the date of purchase

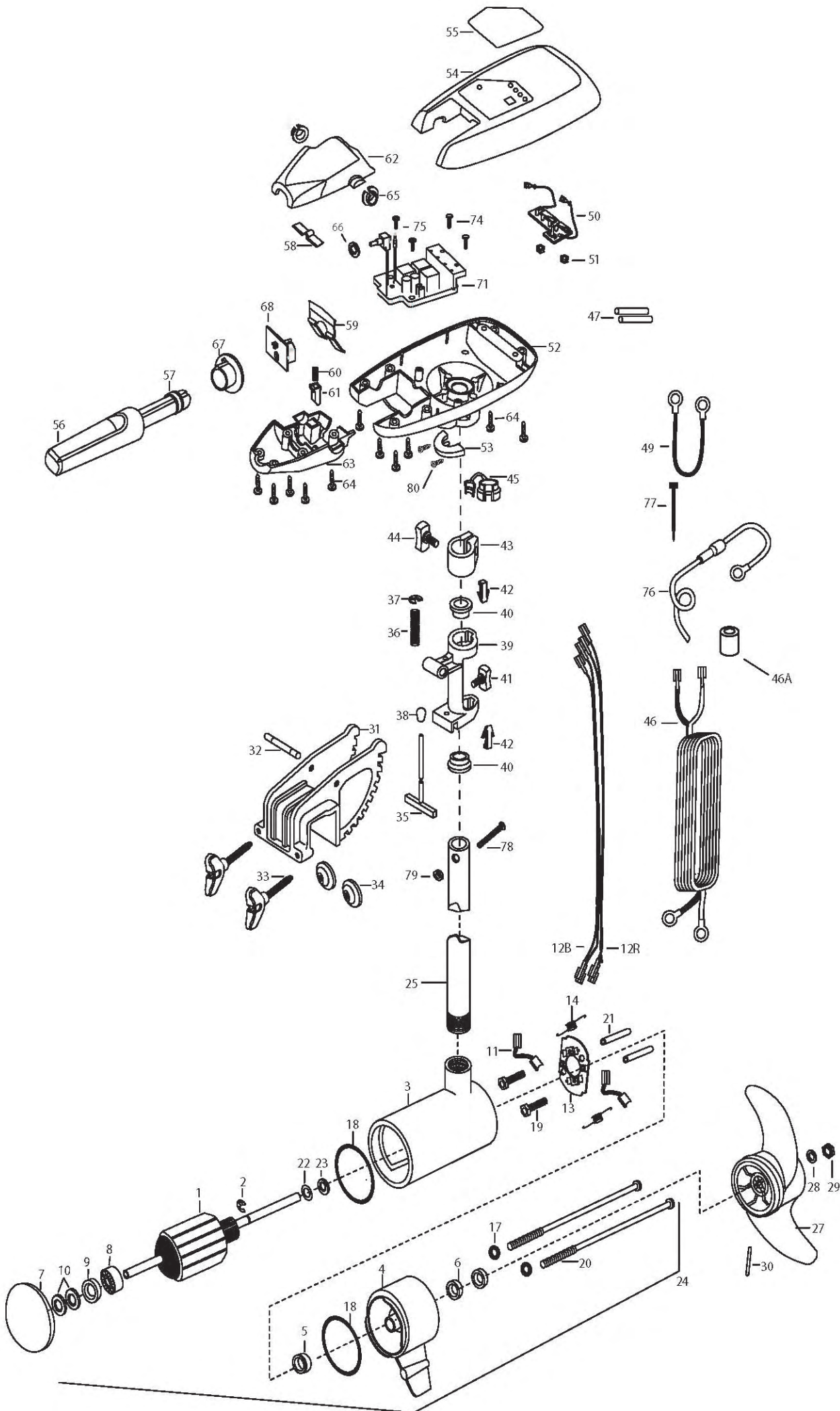

1	2-100-214	ARMATURE ASSEMBLY 24V 4 "	*31	2031901	BRACKET	63	2060415	HANDLE- LOWER HALF
2	788-040	RETAINING RING	32	2010511	PIN-HINGE	64	2303412	SCREW-6-20 X 5/8 SELF TAP [11.EA]
3	431-160	HOUSING ASSEMBLY CENTER 4.0 TXT	*33	2061300	SCREW-CLAMP [2.EA]	65	2060005	BEARING- HANDLE PIVOT
4	2-300-160	BRUSH END HOUSING ASSEMBLY	*34	2011710	WASHER-CLAMP SCREW [2.EA]	66	2181700	WASHER SPACER
5	144-017	BEARING- FLANGE	35	2033600	T-BAR	67	2302852	ACTUATOR- CAM
6	880-025	SEAL [2.EA]	36	2012700	SPRING-T-BAR	68	2184020	POT ADAPTER
7	421-276	PLAIN END HOUSING ASSEMBLY	37	2013000	E-RING	71	2184005	CONTROL BOARD W/O LEAD- 24V
8	140-010	BALL BEARING	38	2010100	KNOB-TILT	74	2043427	SCREW -8-18 X 7/8 SS [2.EA]
9	990-045	THRUST SPACER	39	2031852	HINGE	75	2043427	SCREW- 8-18 X 7/8 SS [2.EA]
10	992-010	SPRING WASHER [2.EA]	40	2037300	BUSHING-HINGE [2.EA]	76	2060310	GROUND WIRE- FUSED
11	186-094	BRUSH 4" [2.EA]	41	2011385	SCREW-TENSION W/NEW KNOB	77	2256300	TIE WRAP 5.5"
12B	640-014	LEADWIRE BLACK 10 AWG 55	42	2062800	TENSION BLOCK [2.EA]	78	2383407	SCREW 10-24X 2
12R	640-119	LEADWIRE RED 10 AWG 56-1/2	43	2061520	COLLAR-DEPTH ENDURA	79	2383124	NUT HEX 10-24 NYLOCK
13	738-004	BRUSH PLATE- 4"	44	2011365	SCREW-COLLAR W/NEW KNOB	80	2263434	SCREW #8 X 1" PPH SS [2.EA]
14	975-041	SPRING- TORSION [2.EA]	45	2052900	STRAIN RELIEF			
17	701-009	O-RING- THRU BOLT [2.EA]	46	2050609	LEADWIRE- 10 GA.			
18	701-043	O-RING [2.EA]	46A	2307310	BEAD - FERRITE [2.EA] (CE MODELS ONLY)			
19	830-027	SCREW- SELF THREAD 10-32X2 [2.EA]	47	2375400	SHRINK TUBE [2.EA]			
20	830-094	THRU BOLT 12 24X 10.31 [2.EA]	49	2340610	CONNECTOR CABLE 12"			
21	973-025	SPACER- BRUSHPLATE [2.EA]	50	2074071	BATTERY GAUGE- 24V			
22	990-051	WASHER- STEEL THRUST	51	2303120	SPEED NUT [2.EA]			
23	990-052	WASHER- NYLATRON	52	2062592	CONTROL BOX FW			
24	2316216	MOTOR ASSEMBLY 24V VARS TXT 4"	53	2061515	COLLAR- CONTROL BOX			
25	2032057	TUBE COMPOSITE 36"	54	2990294	COVER- CNTRL BOX/DECAL ASSMBLY			
	2032053	TUBE COMPOSITE 42"	55	2065662	DECAL- COVER 80T			
■	1378132	PROPELLER KIT	56	2990914	HANDLE ASSEMBLY W/O U-JOINT			
27	2331160	PROPELLER	57	2060000	BEARING- HANDLE [2.EA]			
28	2091701	WASHER- PROP LARGE	58	2302742	SPRING- DETENT OFF SS			
29	2093101	NUT- PROP NYLOC	59	2302743	SPRING- DETENT HANDLE-TILT			
30	2262658	PIN- DRIVE	60	2302745	SPRING- RELEASE BUTTON SS			
■	2991960	BRACKET/HINGE ASSEMBLY INCL. 31-42	61	2303720	RELEASE BUTTON- HANDLE			2889460 seal & oring kit
■	2771901	BRACKET ASSEMBLY INCL. 31, 33,-34	62	2060409	HANDLE- TOP HALF			

* This item is part of an assembly. This item cannot be sold separately due to machining and /or assembly that is required.

P/N 2064947 REV H 3-08

Maxxum 80T is 24-volts only!

wiring diagram for control board #2184003:

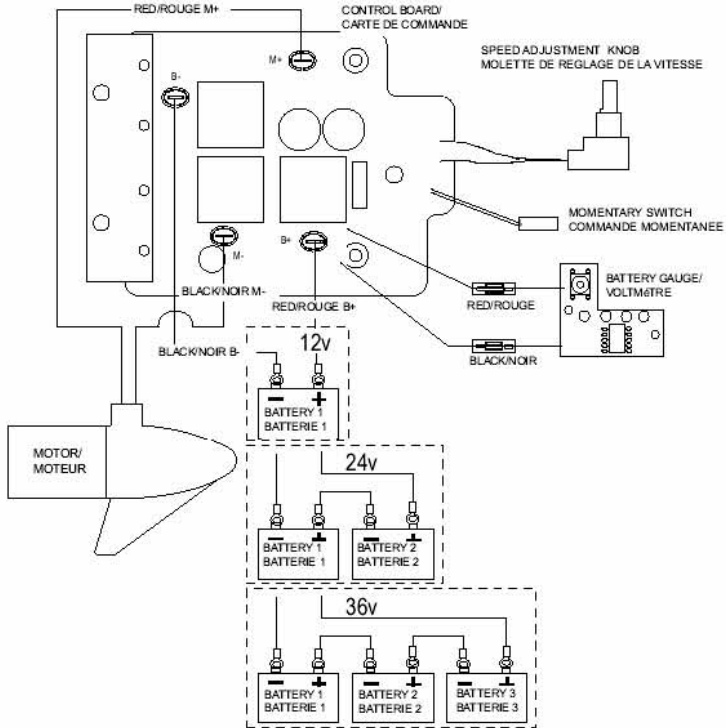

wiring diagram for control board #2184005:

